

未注公差/General tolerances(mm)											0.1/10 ±2'		
0	>3	>6	>10	>18	>30	>50	>80	>120	>180	>250		>315	>400
~ 3	~ 6	~ 10	~ 18	~ 30	~ 50	~ 80	~ 120	~ 180	~ 250	~ 315	~ 400	~ 500	~ 2.50
±0.12	±0.18	±0.22	±0.26	±0.31	±0.37	±0.57	±0.80	±0.93	±1.05	±1.15	±1.60	±2.20	±2.50

please refer to the 3D model, for those unmarked dimensions

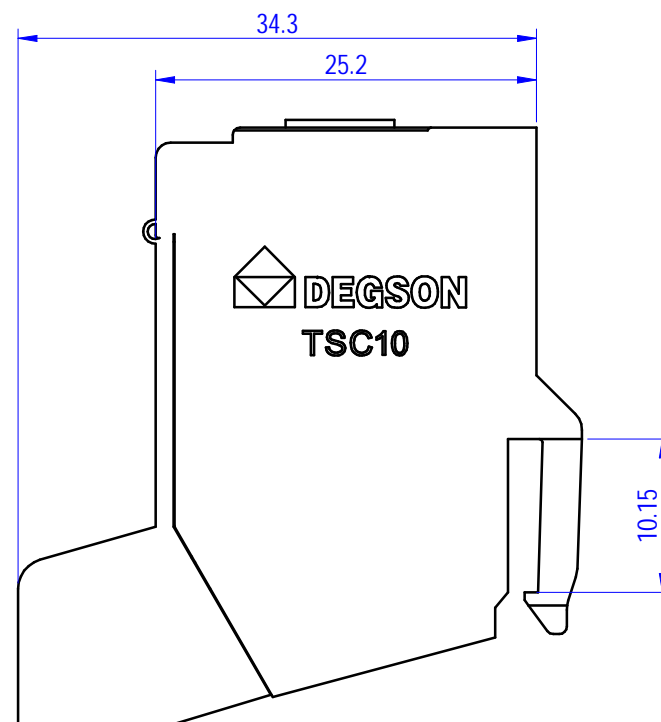
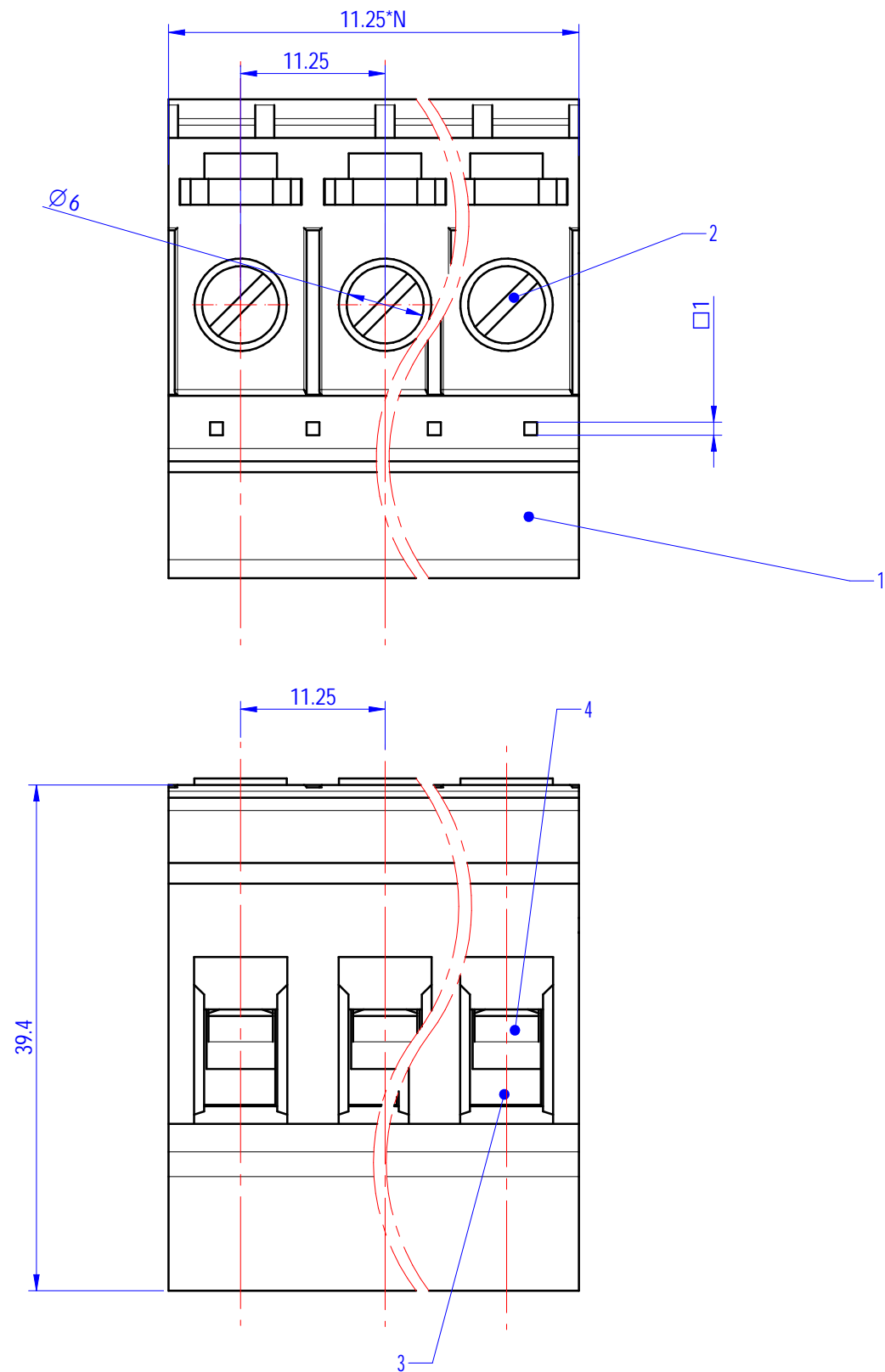
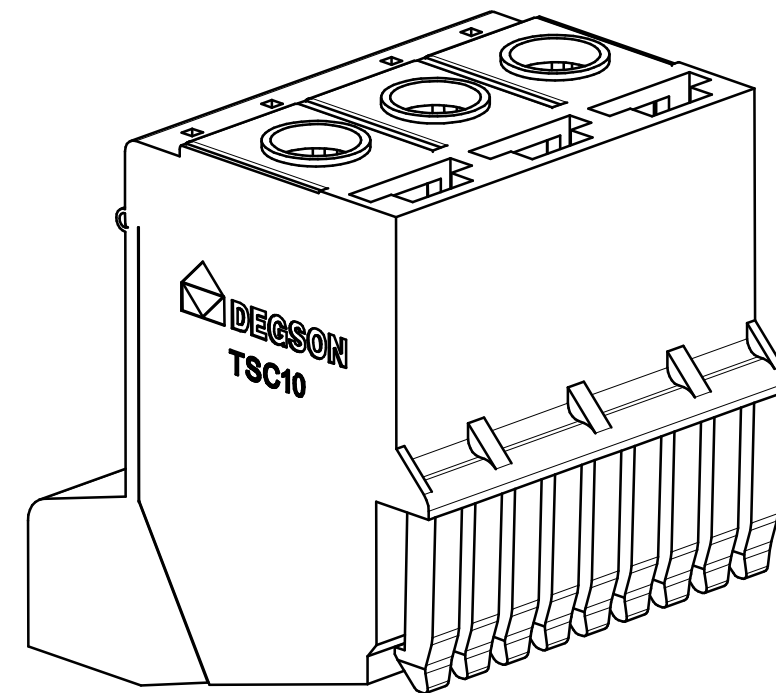

ITEM	NAME OF PART	MATERIAL	NOTES
4	Pin header	Copper alloy	Sn plated
3	Cage	Copper alloy	Ni plated
2	Screw	Steel	Zn plated
1	Housing	PA66	UL94V-0

UL 标准/UL Standard:	B	C	D
额定电压/电流/Rated Voltage(V)/Current(A)	600/65	/	/
IEC 标准/IEC Standard:			
过压类别/Overvoltage Category/污染等级/Pollution Degree	III/3	III/2	II/2
额定电压/电流/Rated Voltage(V)/Current(A)	/	1000/57	/
额定脉冲电压(KV)/Rate Impulse Voltage(KV)	4	4	4
螺丝扭矩/Torque Tightening(N·m/Lb.in)	M4, 1.2/10.63		
线径范围(硬线和软线)/Wire Range(rigid and flexible)(AWG/mm <sup>2</sup> )	24-6 / 0.2-10.0		
间距/Pitch(mm)/线数范围/Poles	11.25/N=02P&03P		
剥线长度/Stripping length(mm)	10-12		
使用温度范围/Operating temperature(°C)	-40~+105		
符合 RoHS 环保要求/Conform to RoHS	Yes		

<b>DEGSON</b>		MATERIAL: 材质	SURFACE/COLOR: 表面处理		
APPD: 核准人		MAT NO./REV: 物料编码 / 版本		MAT STATUS: 物料状态	
CHKD: 审核人		NAME			
DRFT: 设计人		TSC10-XXP-15-500Z(H)			
DRAWING NO.	TYPE	DRAWING STATUS	SCALE	SHEET	
图号	图纸类型	图纸状态	2:1	1/1	

图纸版本	ECN	变更描述	设计人	设计日期
REV	ECN	DESCRIPTION	DRFT	DATE

Transfer or duplication of this document, as well as the utilization or communication of its contents are prohibited unless explicit authorization is granted. Violations will be liable for compensation. All rights reserved for patent. 未经授权复制或传播本文件内容，或未经许可使用、复制或传播本文件内容，均属于侵权行为，本公司保留追究法律责任的权利。 未经授权复制或传播本文件内容，均属于侵权行为，本公司保留追究法律责任的权利。