

未注公差/General tolerances (mm)													D 0.1/10		
0	>3	>6	>10	>18	>30	>50	>80	>120	>180	>250	>315	>400		>500	
~	~	~	~	~	~	~	~	~	~	~	~	~	~		
±0.12	±0.18	±0.22	±0.26	±0.31	±0.37	±0.57	±0.80	±0.93	±1.05	±1.15	±1.60	±2.20	±2.50		
UL 标准/UL Standard:													B	C	D
额定电压/电流/Rated Voltage (V)/Current (A)													300/15	/	300/10
IEC 标准/IEC Standard:															
过压类别/Overvoltage Category/污染等级/Pollution Degree													III/3	III/2	II/2
额定电压/电流/Rated Voltage (V)/Current (A)													/	320/20	/
额定脉冲电压 (KV)/Rate Impulse Voltage (KV)													/	4	/
线径范围 (硬线和软线)/Wire Range (rigid and flexible) (AWG/mm ²)													22~14 / 0.2~2.5		
间距/Pitch (mm)/线数范围/Poles													5.0/N=02~24P		
剥线长度/Stripping length (mm)													9~10		
使用温度范围/Operating temperature (°C)													-40~+105		
符合RoHS环保要求/Conform to RoHS													Yes		

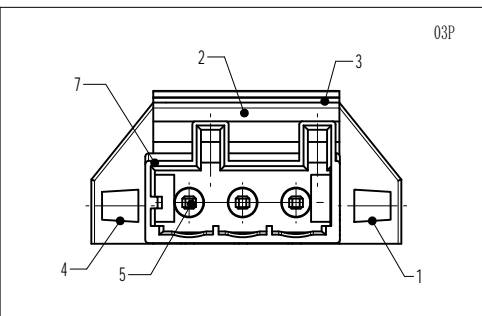
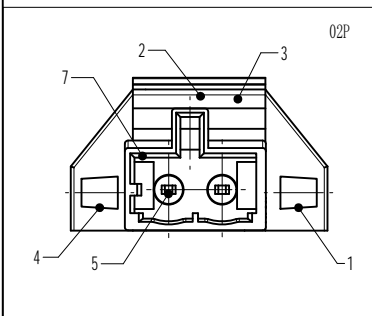
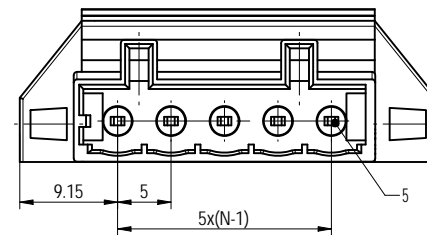
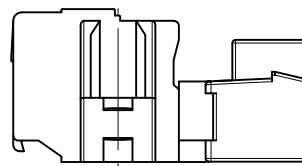
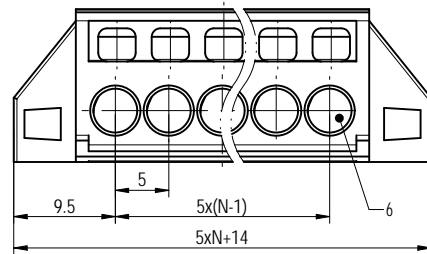
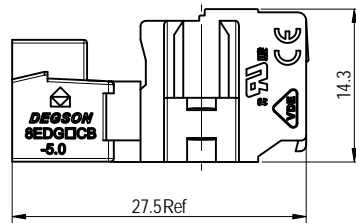
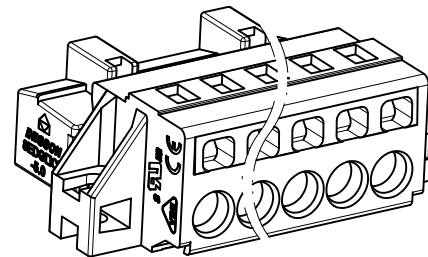
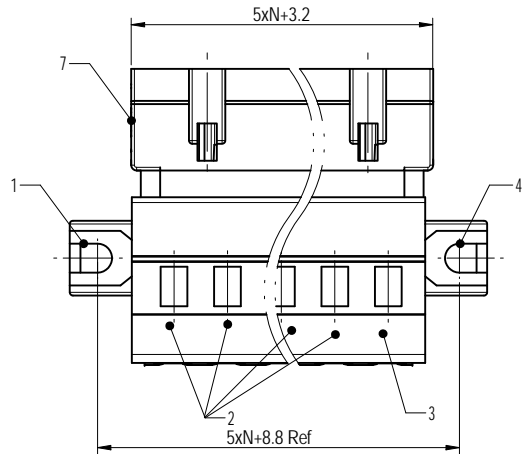

Note:
The A&Z(H) in the name means:A(H) and Z(H).

7	Housing1	PA66	UL94V-0
6	Spring	Stainless Steel	/
5	Pin	Copper	Sn Plated
4	Cover2	PA66	UL94V-0
3	Side housing	PA66	UL94V-0
2	Housing	PA66	UL94V-0
1	Cover1	PA66	UL94V-0
ITEM	NAME OF PART	MATERIAL	NOTES

DIIGSON		MATERIAL:		SURFACE/COLOR: pantone 428C	
APPD: 竺春华		MAT NO./REV: - / 00		MAT STATUS: 批量	
CHKD: 黄耀志		NAME:		8EDGKRM5-5.0-XXP-11-01A&Z(H)	
DRFT: 周锦德		DRAWING NO.:		DRAWING STATUS	
2023.02.23		200021028		已发布	
DATE		TYPE		SCALE	
A3		CUSTOMER DRAWING		2:1	
REV		DESCRIPTION		SHEET	
00				1/1	

Transfer or duplication of this document as well as the utilization of its contents without the written permission of the manufacturer is prohibited. All rights reserved for patent.