

公差表(General tolerances)(mm)											D 0.1/10 N ±2		
0 ~ 3	>3 ~ 6	>6 ~ 10	>10 ~ 18	>18 ~ 30	>30 ~ 50	>50 ~ 80	>80 ~ 120	>120 ~ 180	>180 ~ 250	>250 ~ 315		>315 ~ 400	>400 ~ 500
±0.12	±0.18	±0.22	±0.26	±0.31	±0.37	±0.57	±0.80	±0.93	±1.05	±1.15	±1.60	±2.20	±2.50

(W/O COVER VIEW)

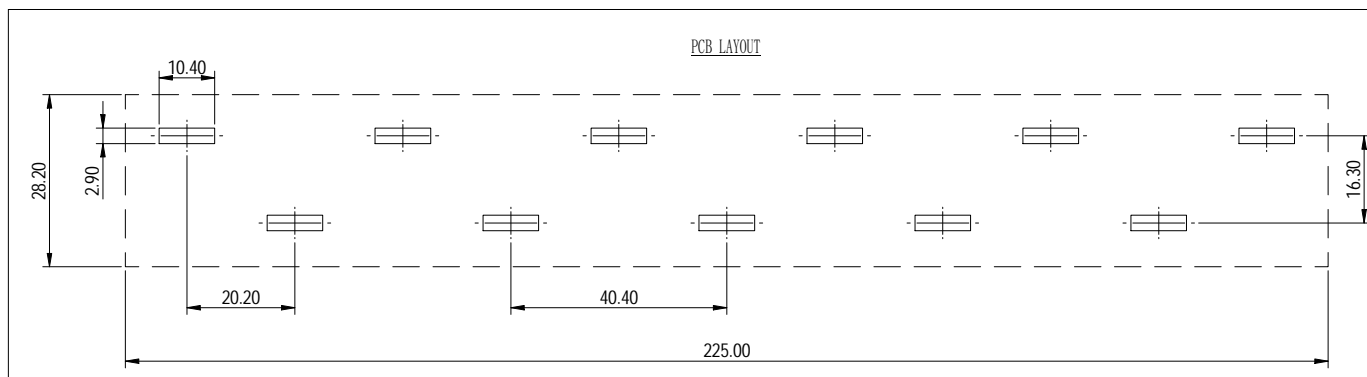
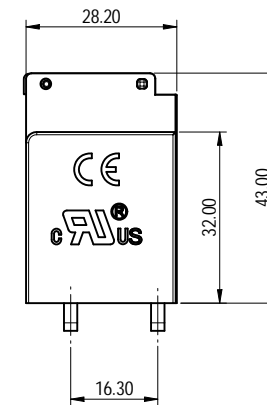
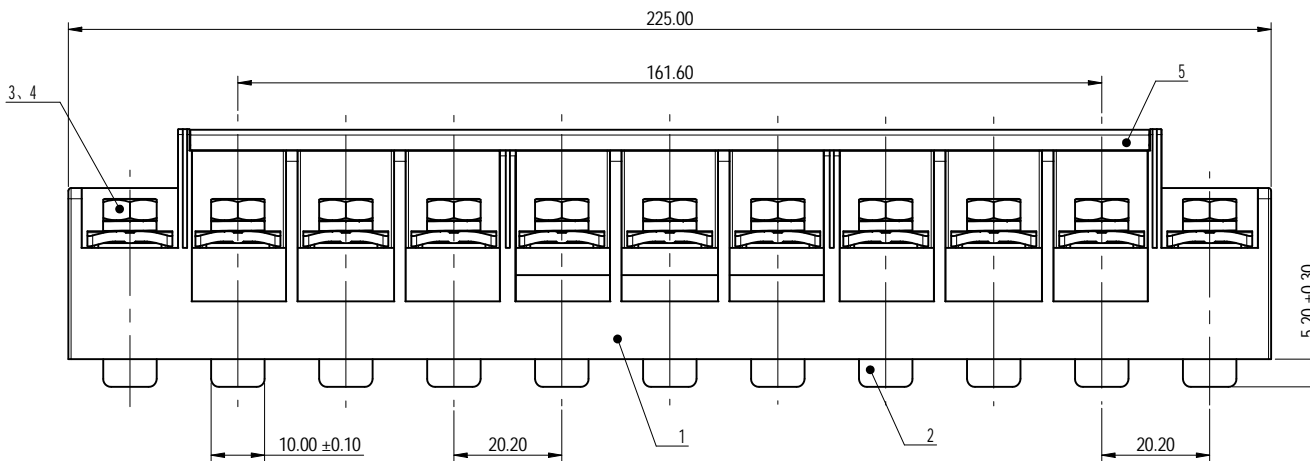
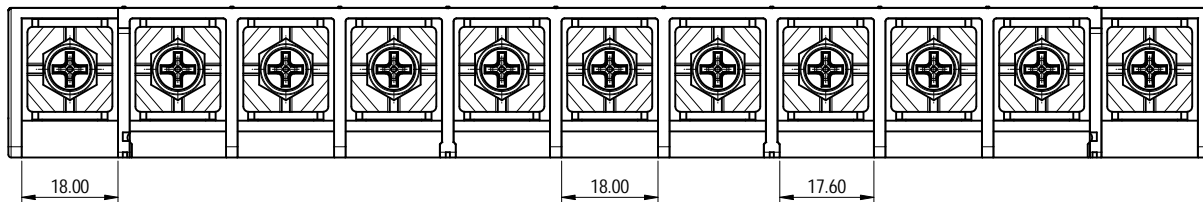

Note: The A&Z (H) in the name means: A(H) and Z (H).

ITEM	NAME OF PART	MATERIAL	NOTES
5	Cover	PC	UL94V-2
4	Nut	Steel	Zn Plated
3	Screw	Steel	Zn Plated
2	Pin header	Copper alloy	Sn Plated
1	Housing	PBT	UL94V-0

UL 标准/UL Standard:	
额定电压/电流/Rated Voltage(V)/Current(A)	600/100
螺丝扭矩/Torque Tightening(N·m/Lb.in)	M6: 7.7/70.0
线径范围(硬线和软线)/Wire Range(rigid and flexible)(AWG)	18~3
间距/Pitch(mm)/线数范围/Poles	20.20/N=11P
剥线长度/Stripping length(mm)	17~19
使用温度范围/Operating temperature(°C)	-40~+120
符合RoHS环保要求/Conform to RoHS	Yes

DEGSON		MATERIAL:	SURFACE:	
APPD: 蓝美凡	2024.04.01	MAT NO./REV: -	/ 00	MAT STATUS: 批量
CHKD: 曹利影	2024.04.01	NAME		
DRFT: 姜民浩	2024.04.01	DG2020-B-11P-1Y-00A&Z(H)		
REV	ECN	DESCRIPTION	DRFT	DATE
00			姜民浩	2024.04.01
DRAWING NO.		TYPE	DRAWING STATUS	SCALE
200018387		CUSTOMER DRAWING	已发布	1:1
SHEET		1/1		

Transfer or duplication of this document as well as the utilization of its contents for any purpose without the written permission of DEGSON is strictly prohibited. All rights reserved for patent, utility, trademark, copyright, and other intellectual property rights. 未经授权复制或传播本文件及其内容，或在本文件基础上进行任何形式的使用，均属于侵权行为。本公司保留所有权利。