

PCB LAYOUT

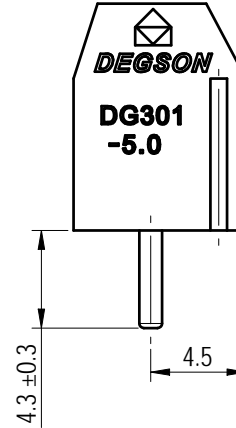

公差/General tolerances (mm)													0.1/10 ±2'
0	>3	>6	>10	>18	>30	>50	>80	>120	>180	>250	>315	>400	
±0.12	±0.18	±0.22	±0.26	±0.31	±0.37	±0.57	±0.80	±0.93	±1.05	±1.15	±1.60	±2.20	±2.50

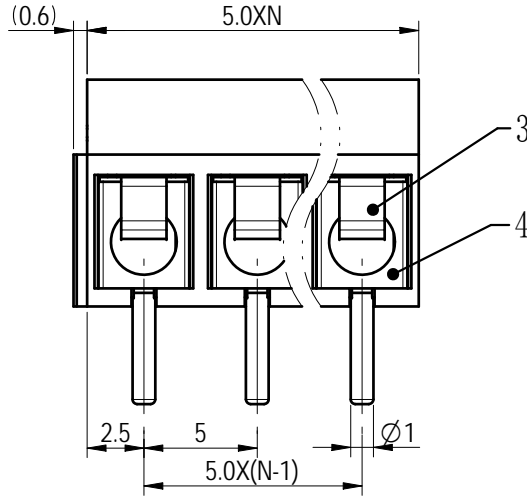
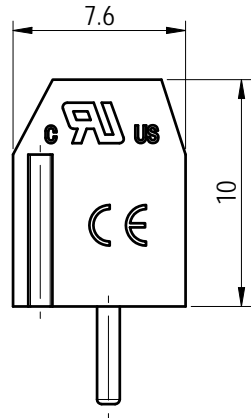
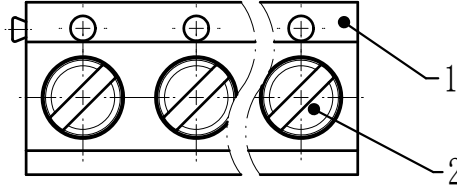
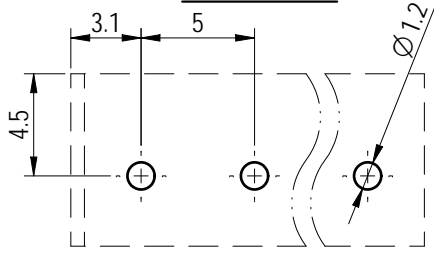
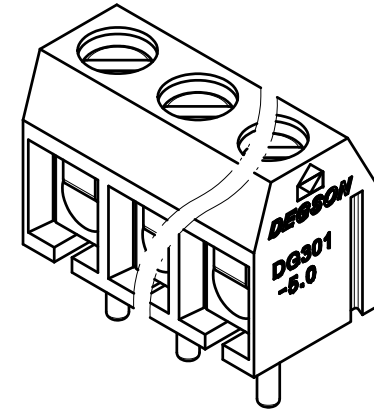

ITEM	NAME OF PART	MATERIAL	NOTES
4	Pin header	Copper alloy	M2.5/Sn plated
3	Spring	Stainless stell	/
2	Screw	Steel	M2.5/Zn plated
1	Housing	PBT	UL94V-0

UL 标准/UL Standard:	B	C	D
额定电压/电流/Rated Voltage(V)/Current(A)	300/15	/	/
IEC 标准/IEC Standard:			
过压类别/Overvoltage Category/污染等级/Pollution Degree	III/3	III/2	II/2
额定电压/电流/Rated Voltage(V)/Current(A)	/	250/17.5	/
工频耐压/Withstanding voltage(V/1Min)	AC2000		
螺丝扭矩/Torque Tightening(N·m/Lb.in)	M2.5, 0.29/2.6		
线径范围(硬线和软线)/Wire Range(rigid and flexible)(AWG/mm²)	22~14 / 0.75~1.5		
间距/Pitch(mm)/线数范围/Poles	5.0/N=02~22P		
剥线长度/Stripping length(mm)	6~7		
使用温度范围/Operating temperature(°C)	-30~+120		
符合RoHS环保要求/Conform to RoHS	Yes		

DEGSON		MATERIAL:	SURFACE/COLOR:	
APPD: 兰春华	2025.03.13	MAT NO./REV:	/ 00	
CHKD: 陈招	2025.03.12	NAME		
DRFT: 龚徐涛	2025.03.12	DG301-5.0-XXP-1Y-00Z(H)		
DRAWING NO.	TYPE	DRAWING STATUS	SCALE	SHEET
200102539	CUSTOMER DRAWING	已发布	3:1	1/1

REV	ECN	DESCRIPTION	DRFT	DATE
03			龚徐涛	2025.03.12

Transfer or duplication of this document as well as the utilization or communication of its contents are prohibited unless authorized in writing by DEGSON. All rights reserved for patent. 除专利注明情况外，其他内容均受版权保护。未经许可，不得复制或传播。 0.1/10