

公差/General tolerances (mm)

0	>3	>6	>10	>18	>30	>50	>80	>120	>180	>250	>315	>400	>500	0.1/10
~3	~6	~10	~18	~30	~50	~80	~120	~180	~250	~315	~400	~500	~500	
±0.12	±0.18	±0.22	±0.26	±0.31	±0.37	±0.57	±0.80	±0.93	±1.05	±1.15	±1.60	±2.20	±2.50	±2'

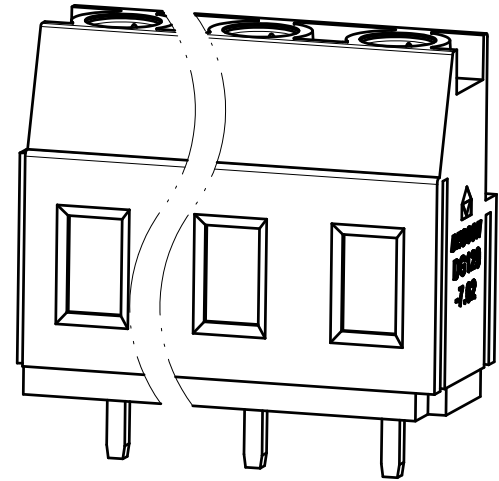

Note: The A&Z(H) in the name means: A(H) and Z(H).

5	Screw	Steel	M3/Zn Plated
4	Cage	Copper alloy	M3/Ni Plated
3	Housing	PA66	UL94V-0
2	Cover	PA66	UL94V-0
1	Pin header	Copper alloy	Sn plated
ITEM	NAME OF PART	MATERIAL	NOTES

UL 标准/UL Standard:		B	C	D
额定电压/电压/Rated Voltage(V)/Current(A)		300/20	/	300/10
IEC 标准/IEC Standard:				
过压类别/Overvoltage Category/污染等级/Pollution Degree		III/3	III/2	II/2
额定电压/电压/Rated Voltage(V)/Current(A)		/	450/20	/
工频耐压/Withstanding Voltage (V/1Min)		AC2500		
螺丝扭矩/Torque Tightening(N·m/Lb.in)		M3, 0.5/4.5		
线径范围(硬线和软线)/Wire Range(rigid and flexible)(AWG/mm²)		26~12/0.5~2.5		
间距/Pitch(mm)/线数范围/Poles		7.62/N=02~16P		
剥线长度/Stripping length(mm)		8		
使用温度范围/Operating temperature(°C)		-40~+105		
符合RoHS环保要求/Conform to RoHS		Yes		

APPD: 兰春华 2022.08.02 CHKD: 陈招 2022.08.02 DRFT: 袁路易 2022.08.02		MATERIAL: -		SURFACE/COLOR:	
		MAT NO./REV: - / 00		MAT STATUS: 批量	
NAME				DG129-7.62-XXP-1Y-100A&Z(H)	
DRAWING NO.		TYPE		DRAWING STATUS	
200022087		CUSTOMER DRAWING		已发布	
SCALE		SHEET			
2.5:1		1/1			

00	袁路易	2022.08.02	袁路易	2022.08.02
REV	ECN	DESCRIPTION	DRFT	DATE