

未注公差/General tolerances(mm)													
0	>3	>6	>10	>18	>30	>50	>80	>120	>180	>250	>315	>400	0.1/10 ±2'
~3	~6	~10	~18	~30	~50	~80	~120	~180	~250	~315	~400	~500	
±0.12	±0.18	±0.22	±0.26	±0.31	±0.37	±0.57	±0.80	±0.93	±1.05	±1.15	±1.60	±2.20	±2.50

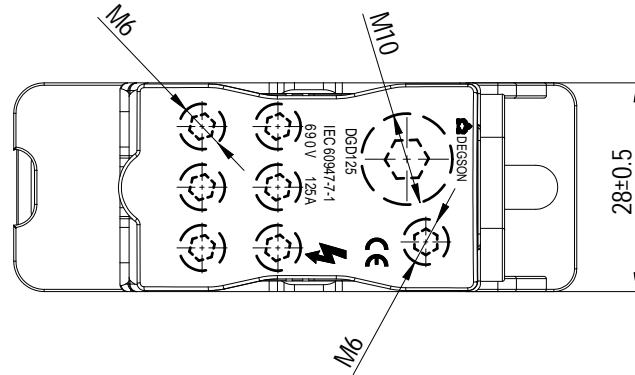
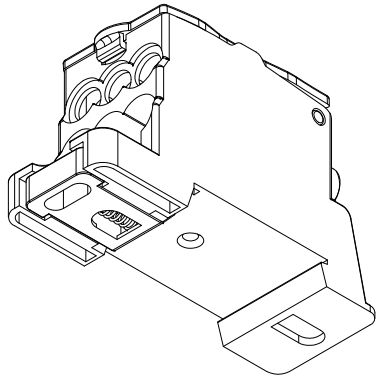
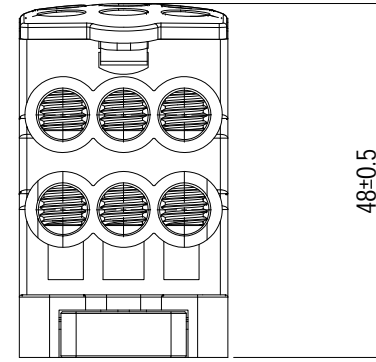
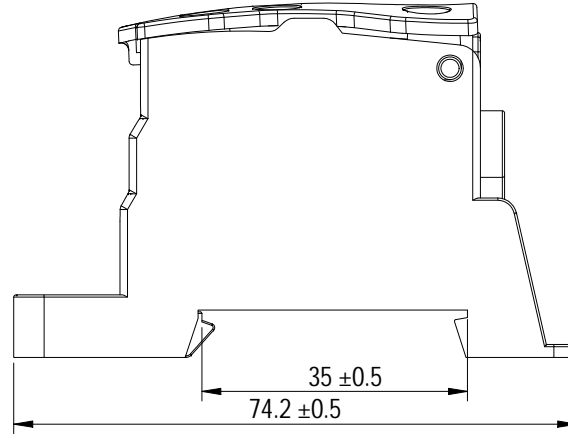
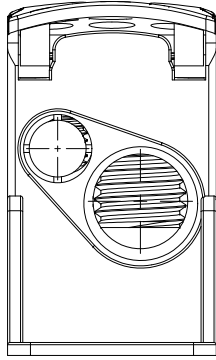

技术要求:

- 产品材质: 塑壳/卡脚: 尼龙(PA)
塑盖: 聚碳酸酯(PC)
导电件: H54黄铜(镀镍)
螺丝: A3钢材(镀镍)
弹簧: 碳素钢
- 额定电压/电流: 690V/125A
- 耐电压: AC 1分钟3000V无击穿
- 阻燃性能: 底座 灼热丝960℃, 阻燃(V-0)
塑盖: 灼热丝850℃, 阻燃(V-2)
- 扭力(N.m): ≤3.0(M6), ≤10(M10)
- 6拉力(N): 2.5mm² ≥50, 4mm² ≥60, 6mm² ≥80, 10mm² ≥90,
16mm² ≥100, 25mm² ≥135, 35mm² ≥190
- 工作环境温度(℃): -40~+85℃
- 导线截面(mm²): 进线: (10-35) 出线: (2.5-16)

		MATERIAL:	SURFACE/COLOR:		
		MAT NO./REV: 30110000047-1 / 01	MAT STATUS: 批量		
APPD: 彭敏	2024.06.05	NAME			
CHKD: 高卫国	2024.06.05	DGD125-01P-11-00A(H)			
DRFT: 黄仁锦	2024.06.05	DRAWING NO.	TYPE	DRAWING STATUS	SCALE
		200253584	CUSTOMER DRAWING	已发布	2:1
					SHEET
					1/1

00		New Product	黄仁锦	2024.06.05
REV	ECN	DESCRIPTION	DRFT	DATE

Transfer or duplication of this document as well as the utilization or communication of its contents are prohibited unless explicit authorization is granted. 未经授权, 任何形式复制或传播本文件内容, 均属于侵权行为。 本公司保留对产品及发明、实用新型和外观设计的所有权利。