

Transfer or duplication of this document as well as the utilization or communication of its contents are prohibited unless authorized in writing by the copyright holder. All rights reserved for patent, utility model or design registrations. 除专利等明确标注外，本文件内容均受法律保护。未经许可，不得复制或传播。如有侵权，本公司保留追究法律责任的权利。

未注公差/General tolerances (mm)													0.1/10 ±2'	
0 ~ 3	>3 ~ 6	>6 ~ 10	>10 ~ 18	>18 ~ 30	>30 ~ 50	>50 ~ 80	>80 ~ 120	>120 ~ 180	>180 ~ 250	>250 ~ 315	>315 ~ 400	>400 ~ 500		>500
±0.12	±0.18	±0.22	±0.26	±0.31	±0.37	±0.57	±0.80	±0.93	±1.05	±1.15	±1.60	±2.20	±2.50	

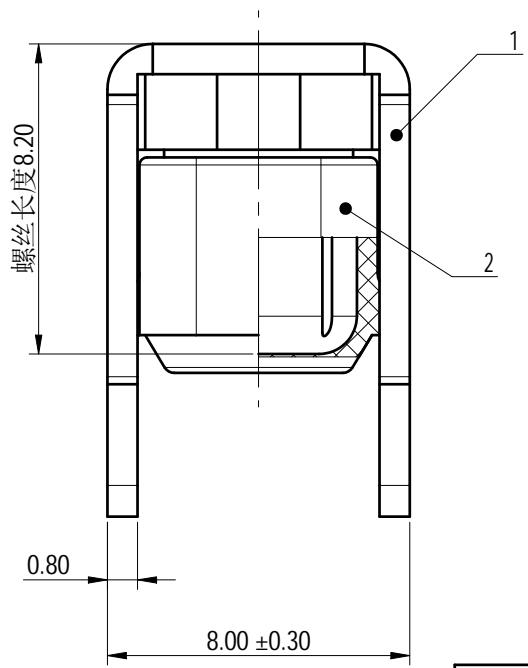
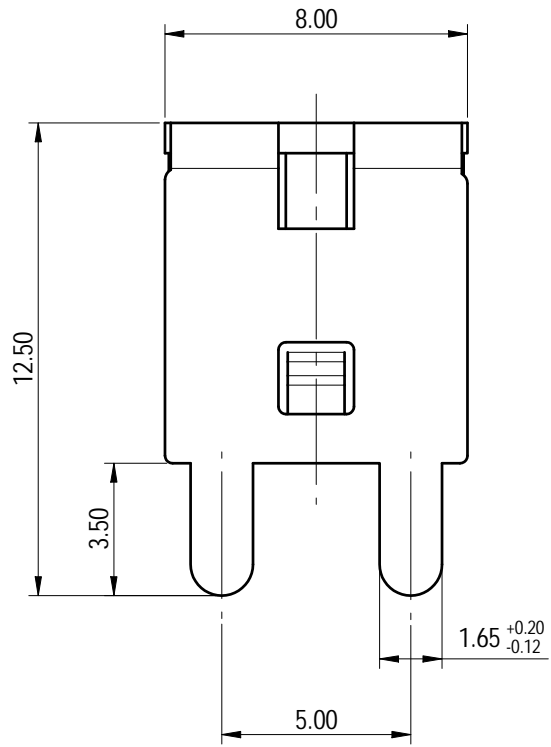
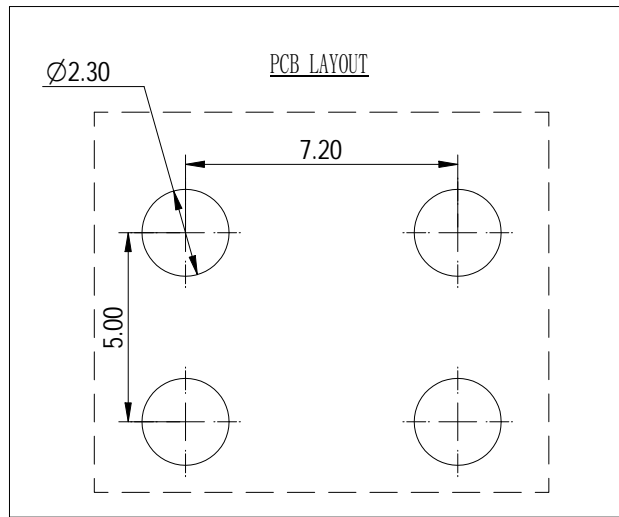
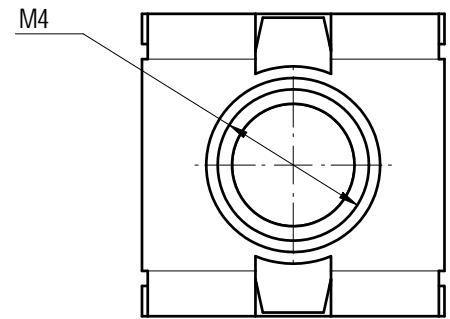

2	Housing	PA66	UL94V-0
1	Pin header	Copper alloy	Sn Plated
ITEM	NAME OF PART	MATERIAL	NOTES
额定电流/Rated Current(A)			50A
螺丝扭矩/Torque Tightening(N·m/Lb.in)			M4, 1.5/13.28
符合RoHS环保要求/Conform to RoHS			Yes

<b>DEGSON</b>		MATERIAL:	SURFACE/COLOR:	
APPD: 蓝贵凡 2023.06.06		MAT NO./REV: 10902000187-1 / 00	MAT STATUS: 批量	
CHKD: 曹利彬 2023.06.06		NAME		
DRFT: 姜民洁 2023.06.06		K145-12Z(H)		
DRAWING NO.	TYPE	DRAWING STATUS	SCALE	SHEET
200196984	CUSTOMER DRAWING	已发布	1:1	1/1

REV	ECN	DESCRIPTION	DRFT	DATE
00			姜民洁	2023.06.06